

CENTROIP SYNCHRO

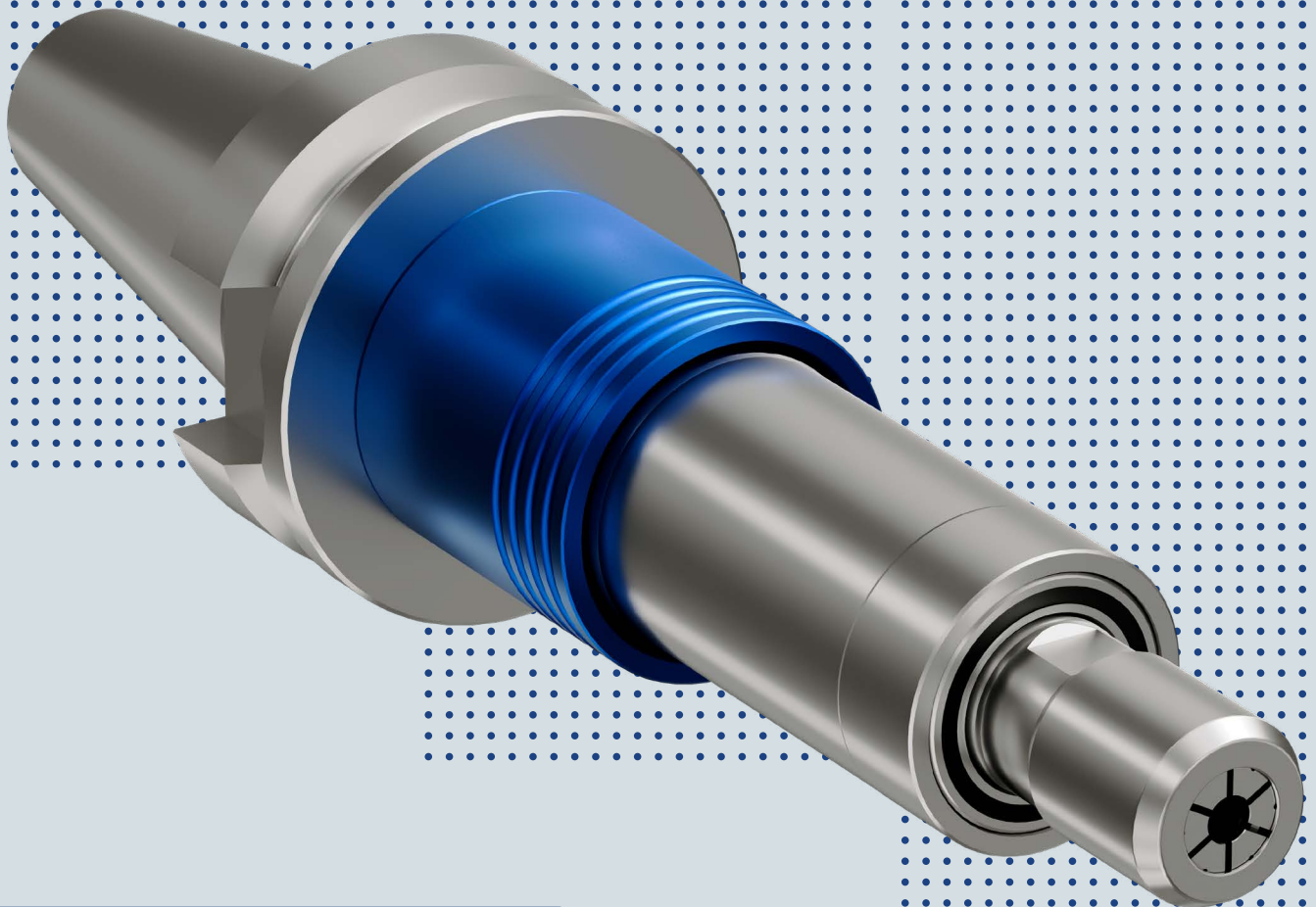

CENTROIP SYNCHRO
CHUCKS EAT UP
COMPRESSIVE FORCES.

This is synchronised thread
machining in perfection.

Decoupling without mechanical friction → Torque load without losing ease of movement

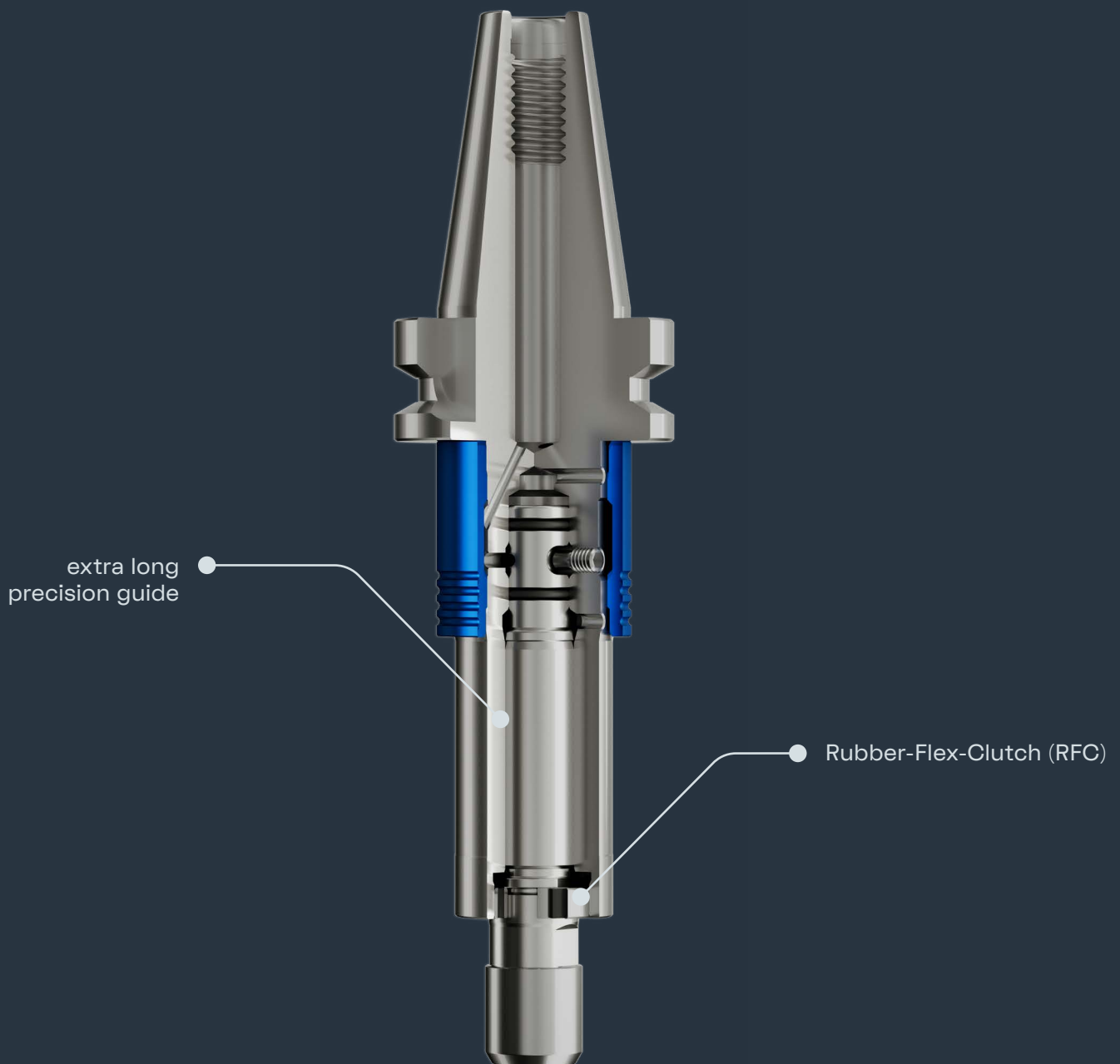

1

More secure
process

2

Significantly longer
tool life

Features

1

Extremely low axial forces for low flank pressure and perfect surface quality.

2

Torsion damper and compensation mechanism in the circumferential direction.

3

Depth of up to 150 mm achievable with Ø10 interfering contour (for thread size M0.5 - M3).

4

Suitable for internal coolant supply of up to 80 bar.

5

Suitable for thread taps and forming taps.

6

Suitable for right-hand and left-hand threads.

7

Suitable for blind and through holes.

8

Minimum length compensation in push and pull direction.

9

Drastically reduces the flank pressure on old and new CNC machining centres.

Benefits

1

Even more stable! More secure processes thanks to smooth operation even under torque load.

2

Even more durable! Longer tool life of the tap and forming tap.

3

Even smaller! Significantly smaller outer diameter than previously available on the market.

4

Even more! 10 times more internal cooling directly on the tool than the best competitor (for ER8).

5

Even more precise! Twice the concentricity for the lowest flank pressure.

6

Even smoother! Damped reversal of direction of rotation for fewer tool breakages.

What a synchro chuck is capable of

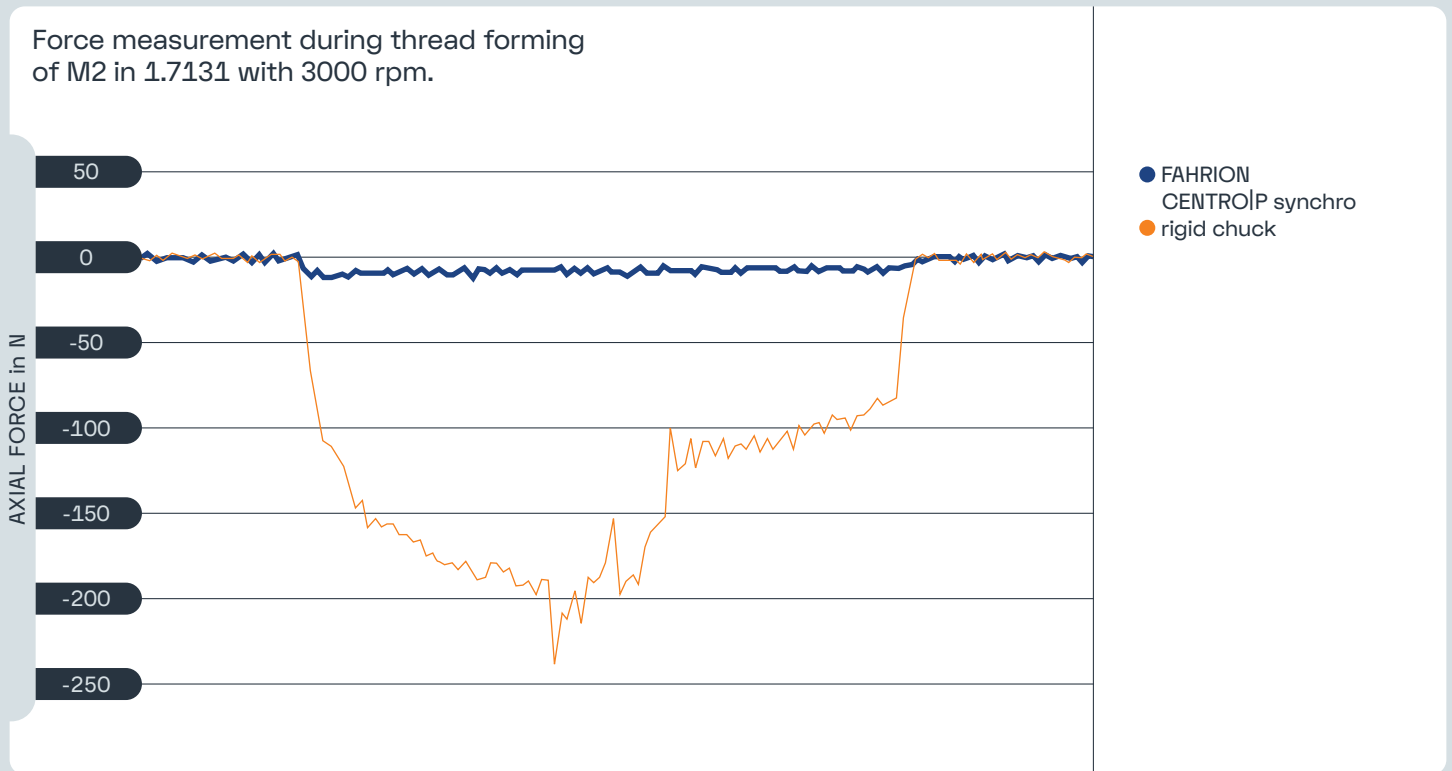

A tapping chuck with minimum length compensation (synchro chuck) compensates for any synchronisation errors that occur and keeps the forces acting on it in check. In order to produce threads reliably, it is crucial that the synchro chuck can maintain its ease of movement, especially under torque load.

The axial forces generated during thread machining can be clearly seen in the diagram: Machining with a rigid chuck (orange line) compared with a chuck including synchronised compensation (blue line).



The general rule is:
The weaker the axial force,
the better the quality, lower
the wear, longer the tool life,
safer the process.

What makes CENTRO|P synchro so unique

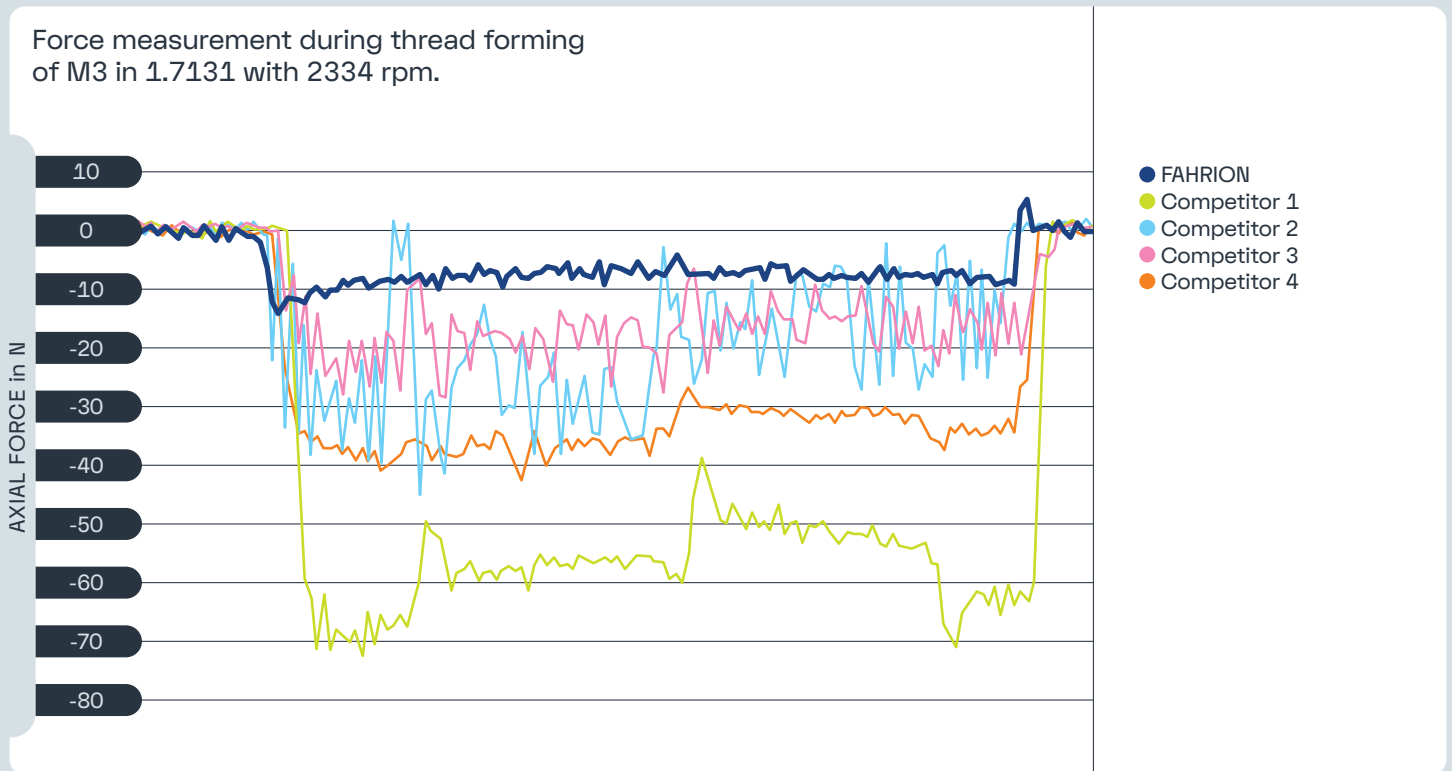

Every mechanical engineer knows: "When turning and pulling at the same time, you get a jam." This is an ongoing basic problem caused by balls, pins or similar drivers under torque load. FAHRION technology simply dispenses with such mechanical positive-locking drivers and instead works with our patent-pending clutch ("Rubber-Flex-Clutch").

The "Rubber-Flex-Clutch" (RFC) allows the tool holder to absorb torque loads without mechanical positive locking. The process of driving and equalisation takes place "in one piece" and is almost frictionless. In addition, the RFC ensures a damped momentum when the direction of rotation is reversed.



The diagram shows 4 chucks with different mechanical synchronised balancers, which we have compared with our RFC technology.



It can be clearly seen that our tapping chuck exhibits the lowest wear-promoting axial forces (dark blue line).

From synchronised compensation in four directions to backlash-free synchronised compensation

Pull and torsional force during thread cutting or forming

→ The RFC acts on the radial drive in the direction of rotation as well as on the axial compensation in both the tensile and compressive directions.

Push and torsional force after reversing the direction of rotation

→ The RFC acts on the radial drive in the reverse direction of rotation as well as on the axial compensation in both the tensile and compressive directions.

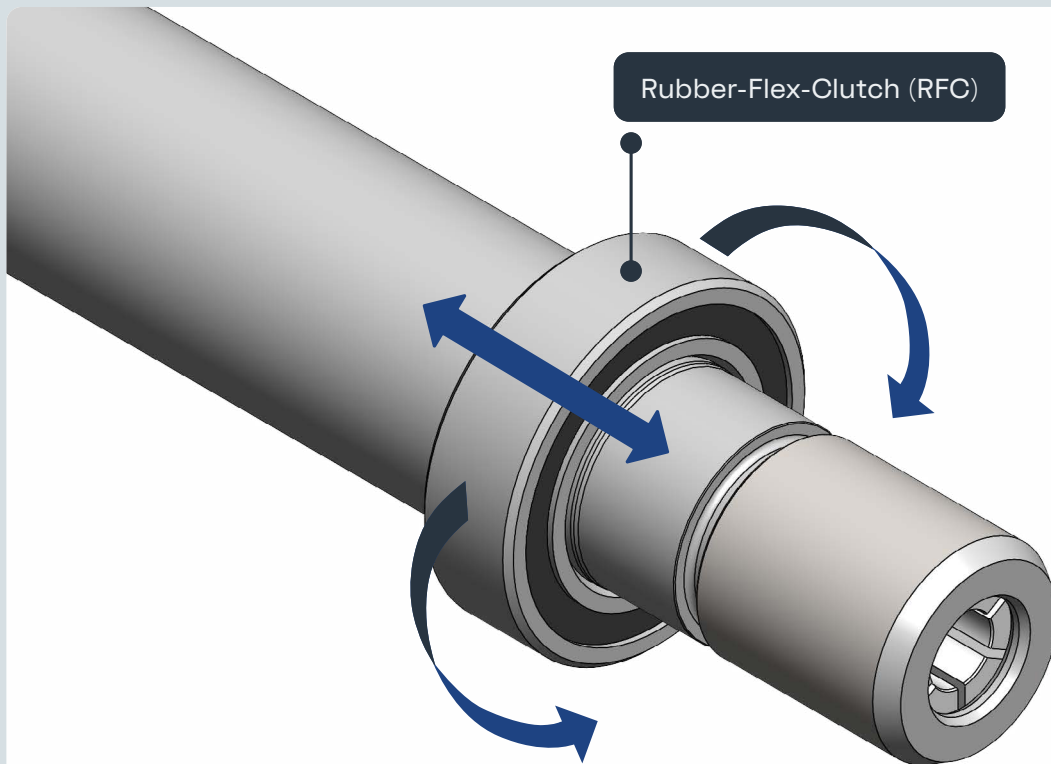

CENTRO|P synchro chucks are characterised by particularly long and precise guidance of the shaft with consistently high FAHRION quality.

Precise and synchronised down to the last corner

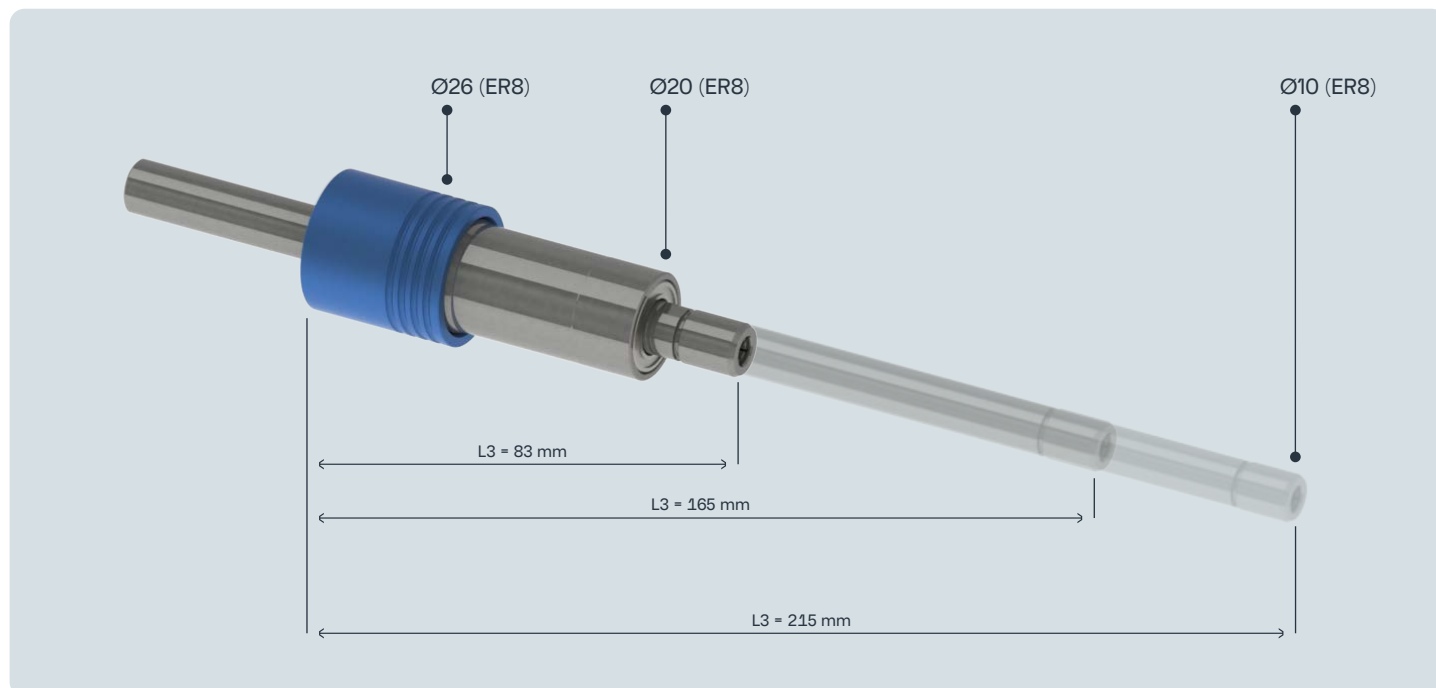

The FAHRION-specific design of the guideways ensures maximum concentricity even with long overhangs. The Rubber-Flex-Clutch (RFC) provides the necessary damping properties in the axial and radial directions. Our Mini Synchro Chuck MSC8 only requires a diameter

of 10 mm on the clamping nut. A unique feature of the extended CENTROIP synchro versions is that, despite their extremely slim outer contour, they have an internal coolant supply system.

Many advantages thanks to internal cooling lubricant supply



A sufficient quantity of coolant at the right pressure in the right place is essential for threading. It is therefore usually advantageous if the coolant is channelled through the tool.

As shown schematically in the pictures, an internal cooling lubricant supply ensures that there is always enough cooling lubricant directly at the cutting edge, even with critical contours. The outlet can either be through the tool and/or through the collet.

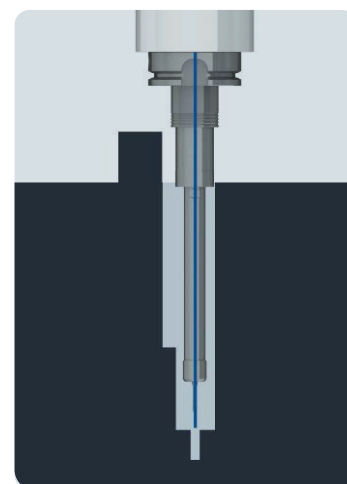

The CENTRO|P synchro product range at a glance

ZYL

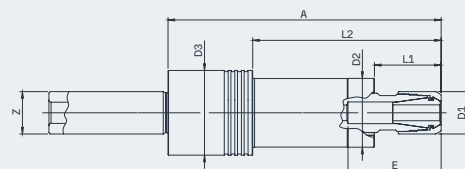
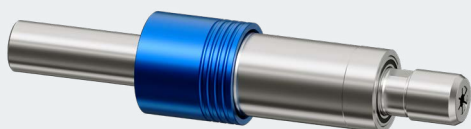

DESCRIPTION	ORDER-NO.	ER-SIZE	INTER-FACE		LENGTH		THREAD RANGE	D1 = WRENCH Ø	D2	D3	L1	L2	L3	E
					SHAFT	A-SIZE								
MSC8-Z10-A=83	53010340831	ER8	Z10	IC	18	83	M0,5 - M3	10	20	26	18	55	=A	25
MSC8-Z10-A=165	53010341651	ER8	Z10	IC	100	165	M0,5 - M3	10	20	26	100	137	=A	25
MSC8-Z10-A=215	53010342151	ER8	Z10	IC	150	215	M0,5 - M3	10	20	26	150	187	=A	25
MSC11-Z16-A=103	53031341031	ER11	Z16	IC	25	103	M3 - M6	16	26	32	25	71	=A	35
MSC11-Z16-A=228	53031342281	ER11	Z16	IC	150	228	M3 - M6	16	26	32	150	196	=A	35
MSC11-Z16-A=278	53031342781	ER11	Z16	IC	200	278	M3 - M6	16	26	32	200	246	=A	35

HSK-A (ISO 12164-1)

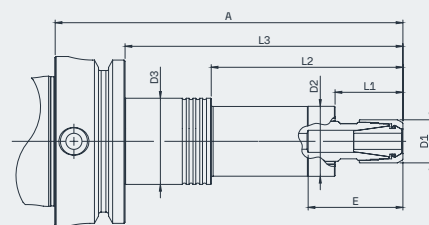

DESCRIPTION	ORDER-NO.	ER-SIZE	INTER-FACE		LENGTH		THREAD RANGE	D1 = WRENCH Ø	D2	D3	L1	L2	L3	E
					SHAFT	A-SIZE								
MSC8-HSK-A63-A=109	54160341091	ER8	HSK-A63	IC	18	109	M0,5 - M3	10	20	26	18	55	83	25
MSC8-HSK-A63-A=191	54160341911	ER8	HSK-A63	IC	100	191	M0,5 - M3	10	20	26	100	137	165	25
MSC8-HSK-A63-A=241	54160342411	ER8	HSK-A63	IC	150	241	M0,5 - M3	10	20	26	150	187	215	25
MSC11-HSK-A63-A=129	54161341291	ER11	HSK-A63	IC	25	129	M3 - M6	16	26	32	25	71	103	35
MSC11-HSK-A63-A=254	54161342541	ER11	HSK-A63	IC	150	254	M3 - M6	16	26	32	150	196	228	35
MSC11-HSK-A63-A=304	54161343041	ER11	HSK-A63	IC	200	304	M3 - M6	16	26	32	200	246	278	35

SK (ISO 7388-1 Form AD)

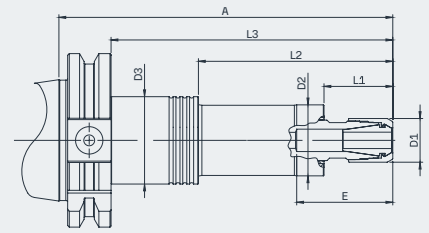

DESCRIPTION	ORDER-NO.	ER-SIZE	INTER-FACE		LENGTH		THREAD RANGE	D1 = WRENCH Ø	D2	D3	L1	L2	L3	E
					SHAFT	A-SIZE								
MSC11-AD40-A=122	53141341221	ER11	SK40	IC	25	122	M3 - M6	16	26	32	25	71	103	35
MSC11-AD40-A=247	53141342471	ER11	SK40	IC	150	247	M3 - M6	16	26	32	150	196	228	35
MSC11-AD40-A=297	53141342971	ER11	SK40	IC	200	297	M3 - M6	16	26	32	200	246	278	35

BT (ISO 7388-2 Form JD)

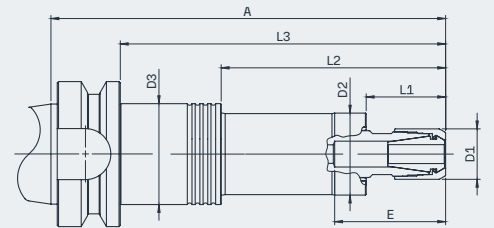
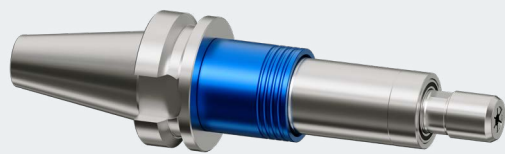

DESCRIPTION	ORDER-NO.	ER-SIZE	INTER-FACE		LENGTH		THREAD RANGE	D1 = WRENCH Ø	D2	D3	L1	L2	L3	E
					SHAFT	A-SIZE								
MSC8-BT30-A=105	53420341051	ER8	BT30	IC	18	105	M0,5 - M3	10	20	26	18	55	83	25
MSC8-BT30-A=187	53420341871	ER8	BT30	IC	100	187	M0,5 - M3	10	20	26	100	137	165	25
MSC8-BT30-A=237	53420342371	ER8	BT30	IC	150	237	M0,5 - M3	10	20	26	150	187	215	25
MSC11-BT30-A=125	53421341251	ER11	BT30	IC	25	125	M3 - M6	16	26	32	25	71	103	35
MSC11-BT30-A=250	53421342501	ER11	BT30	IC	150	250	M3 - M6	16	26	32	150	196	228	35
MSC11-BT30-A=300	53421343001	ER11	BT30	IC	200	300	M3 - M6	16	26	32	200	246	278	35
MSC11-BT40-A=130	53441341301	ER11	BT40	IC	25	130	M3 - M6	16	26	32	25	71	103	35
MSC11-BT40-A=255	53441342551	ER11	BT40	IC	150	255	M3 - M6	16	26	32	150	196	228	35
MSC11-BT40-A=305	53441343051	ER11	BT40	IC	200	305	M3 - M6	16	26	32	200	246	278	35

BTP (BT with Face Contact = similar to ISO 7388-2 Form JD)

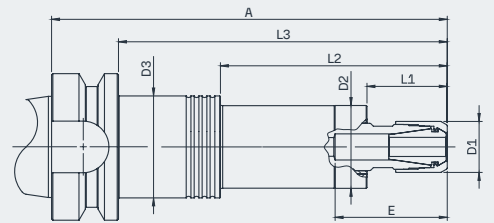
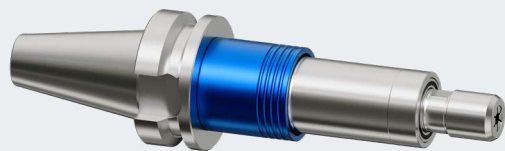

DESCRIPTION	ORDER-NO.	ER-SIZE	INTER-FACE		LENGTH		THREAD RANGE	D1 = WRENCH Ø	D2	D3	L1	L2	L3	E
					SHAFT	A-SIZE								
MSC8-BTP30-A=105	53430341051	ER8	BTP30	IC	18	105	M0,5 - M3	10	20	26	18	55	83	25
MSC8-BTP30-A=187	53430341871	ER8	BTP30	IC	100	187	M0,5 - M3	10	20	26	100	137	165	25
MSC8-BTP30-A=237	53430342371	ER8	BTP30	IC	150	237	M0,5 - M3	10	20	26	150	187	215	25
MSC11-BTP30-A=125	53431341251	ER11	BTP30	IC	25	125	M3 - M6	16	26	32	25	71	103	35
MSC11-BTP30-A=250	53431342501	ER11	BTP30	IC	150	250	M3 - M6	16	26	32	150	196	228	35
MSC11-BTP30-A=300	53431343001	ER11	BTP30	IC	200	300	M3 - M6	16	26	32	200	246	278	35

Suitable FAHRION high-precision collets at a glance

FOR MSC8

HIGH-PRECISION COLLETS GERC8-HP

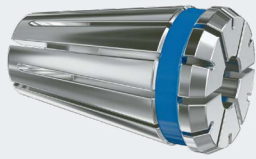

GERC8-HP Ø 1-5 mm

STANDARD

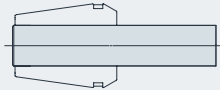
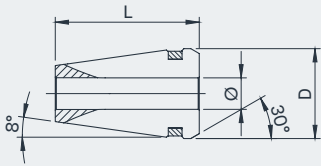

□ = 5 µm

D = 8,5 mm

L = 13,6 mm

Clamping diameter bridging

h9

Ø mm	ORDER-NO.	Ø inch	ORDER-NO.
1,0	13610010100	1/16"	13610040159
1,5	13610010150	1/8"	13610040318
2,0	13610010200	3/16"	13610040476
2,5	13610010250		
2,8	13610010280		
3,0	13610010300		
3,5	13610010350		
4,0	13610010400		
4,5	13610010450		
5,0	13610010500		

FOR MSC11

HIGH-PRECISION COLLETS GERC11-HP



GERC11-HP Ø 1-7 mm

STANDARD

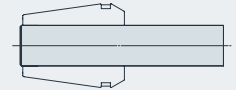
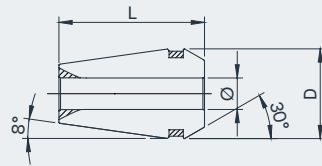

□ = 2 µm

D = 11,3 mm

L = 18,0 mm

Clamping diameter bridging

h9

Ø mm	ORDER-NO.	Ø inch	ORDER-NO.
1,0	13611010100	1/16"	13611040159
1,5	13611010150	3/32"	13611040238
2,0	13611010200	1/8"	13611040318
2,5	13611010250	5/32"	13611040397
2,8	13611010280	3/16"	13611040476
3,0	13611010300	7/32"	13611040556
3,5	13611010350	1/4"	13611040635
4,0	13611010400		
4,5	13611010450		
5,0	13611010500		
5,5	13611010550		
6,0	13611010600		
6,5	13611010650		
7,0	13611010700		

FOR MSC11

HIGH-PRECISION COLLETS GERC11-HPD

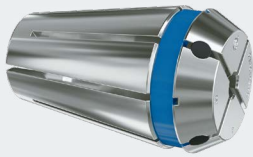

GERC11-HPD Ø 3-6 MM

SEALED FOR INNER COOLANT SUPPLY

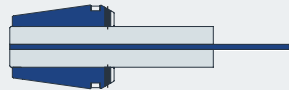
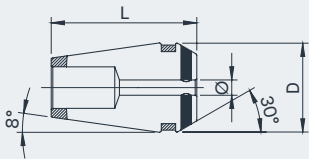

□ = 2 μm

D = 11,3 mm

L = 18,0 mm

Clamping diameter bridging

h9

Ø mm	ORDER-NO.	Ø inch	ORDER-NO.
3,0	13621010300	1/8"	13621040318
4,0	13621010400	3/16"	13621040476
5,0	13621010500	1/4"	13621040635
6,0	13621010600		

HIGH-PRECISION COLLETS GERC11-HPDD



GERC11-HPDD Ø 3-6 MM

SEALED FOR INNER COOLANT SUPPLY WITH JET HOLES

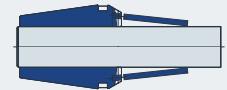
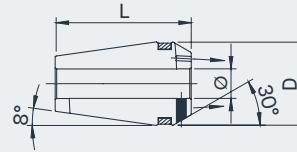

□ = 2 μm

D = 11,3 mm

L = 18,0 mm

Clamping diameter bridging

h9

Ø mm	ORDER-NO.	Ø inch	ORDER-NO.
3,0	13631010300	1/8"	13631040318
4,0	13631010400	3/16"	13631040476
6,0	13631010600	1/4"	13631040635

WHY HIGH-PRECISION COLLETS FROM THE HP SERIES?

HP collets achieve the following advantages in combination with the integrated CENTRO|P technology (collet sits completely in the cone, stable trapezoidal thread, precisely ground double guide):

- Optimum concentricity and surface quality
- Avoidance of tool breakage
- High productivity and process reliability

Have we convinced you?

Benefit now and make your threading process more reliable or increase the service life of your tools.

CONTACT



Thomas Eßwein
t.esswein@fahrion.de
+49 (0)170 2 9513 14



Peter Schwenger
p.schwenger@fahrion.de
+49 (0)151 18 51518 3